











Instructions for use
 Mode d'emploi
 Bedienungsanleitung
 Istruzioni per l'uso
 Gebruiksaanwijzing
 Instrucciones de manejo

DXT SERIES

	DXT1	DXT2	DXT3	DXT4	DXT6
professional					
enhanced					
basic					



PAC 
 PAC REMOTE TRAINERS





Congratulations on buying a PAC RemoteTrainer. PAC has over 17 years of experience in the design, manufacture and supply of dog training and containment equipment for professionals, enthusiasts and pet owners. Many thousands of PAC clients will testify to our enormous success through innovation, reliability and service. The advanced DXT series is the world's most versatile and effective, making PAC's digital remote trainers the de facto "best of breed".



Félicitations pour avoir choisi un système d'entraînement PAC. PAC possède plus de 17 ans d'expérience dans la fabrication de colliers électroniques de rappel. Son succès il le doit à sa haute technologie, sa fiabilité exceptionnelle et la qualité de son service après vente. Les colliers de rappel PAC ont été développés pour répondre au mieux à vos aspirations mais aussi au confort de votre chien. Votre nouveau collier de rappel PAC vous rendra d'appréciables services et vous apportera de remarquables résultats comme pourront vous le confirmer les nombreux heureux possesseurs de matériel PAC. PAC est persuadé que les possibilités de ce modèle dépasseront largement vos espérances et espère pouvoir vous apporter dans le futur d'autres produits éducatifs pour votre chien.



Wir gratulieren Ihnen zum Kauf des PAC-Trainer. Die Firma PAC hat über 17 Jahren Erfahrung mit der Entwicklung, Herstellung und Vertrieb von Hundefemtrainern für Profiausbilder im Schutz- und Jagdhundbereich. Tausende unserer Kunden schätzen unsere Trainer. Dieser Erfolg begründet sich vor allem durch ständige Verbesserungen, Zuverlässigkeit und Bedienkomfort. Die vorgeschrittene AXT Reihe ist ein Innovatives Produkt mit einzigartigen Elementen in der Handhabung.



Congratulazioni per aver scelto un sistema di addestramento PAC ! PAC da 17 anni opera nel settore della produzione di collari elettronici ed ha raggiunto il successo grazie alla tecnologia , all'affidabilità e ad un'eccellente assistenza post-vendita . I sistemi PAC sono ideati pensando costantemente a Lei ed al Suo cane : i nostri prodotti Le daranno un servizio affidabile e risultati eccellenti come testimoniato dall'apprezzamento di tutti i nostri clienti. PAC e' sicura che questo prodotto superera' ogni Sua aspettativa e speranza al punto che non potra' non desiderare in futuro un altro articolo della gamma PAC nel campo dell'addestramento dei cani.



Gefeliciteerd met de aanschaf van Uw PAC Remote Trainer. PAC heeft meer dan 17 jaar ervaring in de ontwikkeling en productie van elektronische hulpmiddelen voor professionals, hobbyisten en gefrustreerde huishond bezitters. Vele duizenden PAC gebruikers getuigen van het enorme succes, wat zich kenmerkt door Innovatie, betrouwbaarheid en service. De AXT serie bestaande uit geavanceerde, digitale trainers zijn niet alleen de meest humane en effectieve, maar ook hun prijs maakt hen mede tot "best of breed". Al deze voordelen zijn typerend voor alle PAC producten !



Enhorabuena por haber adquirido el PAC Remote Trainer. PAC tiene mas de 17 años de experiencia en diseño, fabricación y distribución de productos para el adiestramiento profesional de perros. Miles de cliente recomiendan nuestro producto por su calidad e innovación. AXT es la serie mas avanzada, versatile y efectiva que existe ahora mismo en el Mercado.



www.pacdog.com
info@pacdog.com
support@pacdog.com

made in EU
printed in EU
© PAC Products Ltd. 2006



PAC REMOTE TRAINERS

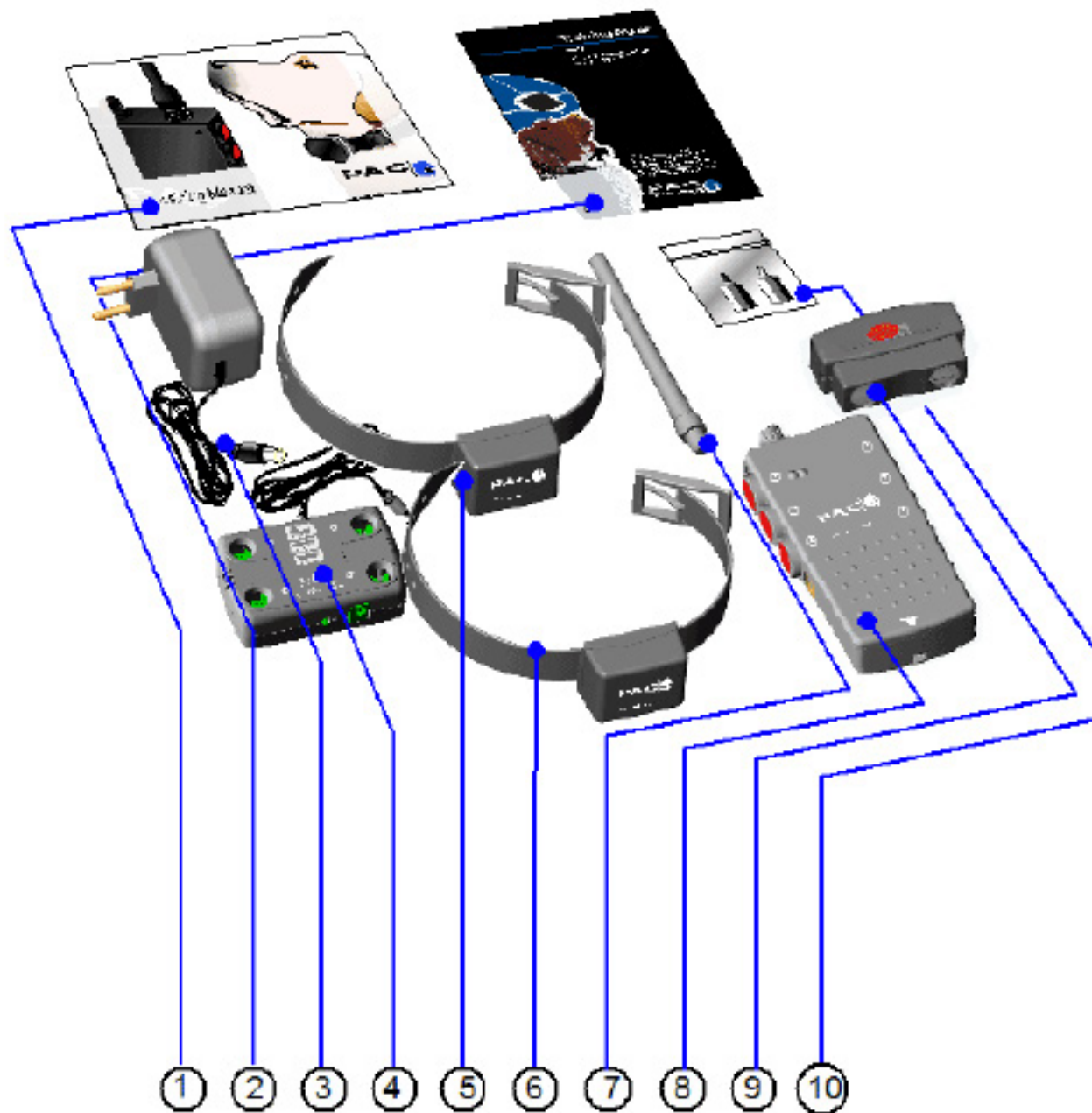

1. Operating Instructions
2. Training Guide (Optional)
3. Mains Power Adaptor
4. Charging Dock
5. Active Collar
6. Dummy Collar (Optional)
7. Antenna
8. Transmitter Handset
9. Neon Tester
10. Pointed Probes(see p.3)



1. Guide d'utilisation
2. Guide d'entraînement (optionnel)
3. Transfo
4. Boîtier de recharge
5. Collier de dressage
6. Collier factice (optionnel)
7. Antenne
8. Télécommande
9. Lampe test
10. Contacts (voir page 3)



1. Bedienungsanleitung
2. Bedienungsanleitung (option)
3. Netzadapter
4. Ladegerät (mit Timer)
5. Empfänger Halsband
6. Attrappen Halsband (Option)
7. Antenne
8. Sender
9. Neonprüfgerät
10. Kontakte für langhaarige Hunde



1. Manuale Operativo
2. Manuale d'addestramento (opzionale)
3. Alimentatore/Adattatore
4. Unita' di ricarica
5. Collare attivo
6. Collare finto (opzionale)
7. Antenna
8. Radiocomando
9. Neon Tester
10. Sonde per pelo lungo



1. Gebruikers Handleiding
2. Trainings Handleiding (optie)
3. Netspanning adapter
4. Laadstation met tijdschakeling
5. Correctie band
6. Dummy band (optie)
7. Antenne
8. Zender (handset)
9. Neon test lamp
10. Extra stiften (lang)



1. Manuale Operativo
2. Guía de entrenamiento (opcional)
3. 'Power unit'
4. 'Charging dock'
5. Collar activo
6. Collar passivo (opcional)
7. Antena
8. Manual
9. Comprobador neon
10. Sonda pelo long



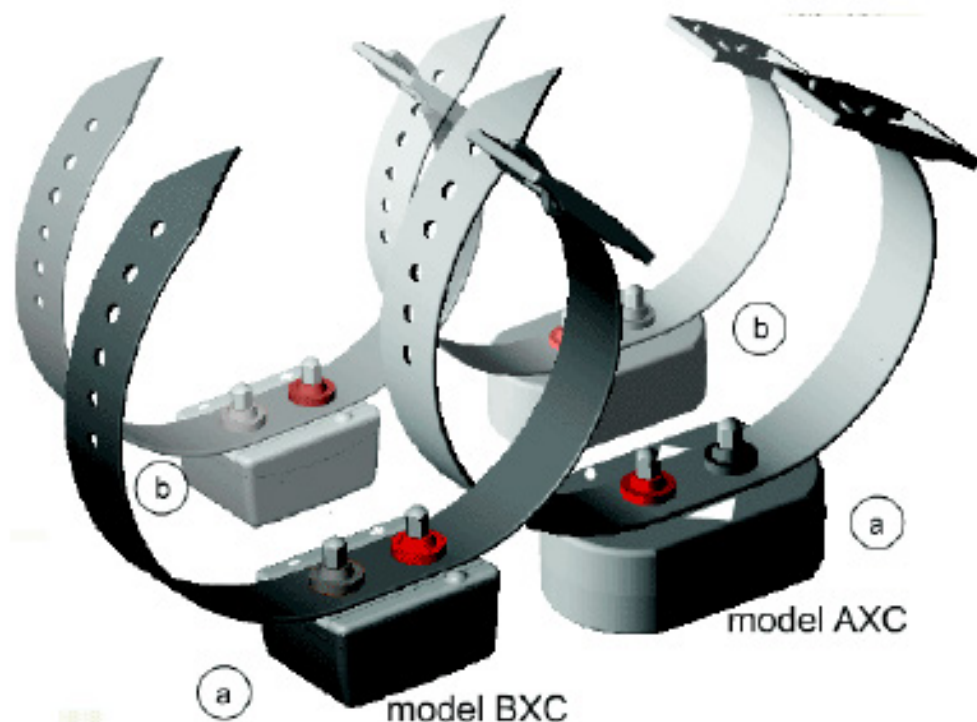

- a. Active Collar
- b. Dummy Collar
- c. Installed Probes for short-haired breeds
- d. Long probes for hairy breeds



- a. Collier de dressage
- b. Collier factice
- c. Contacts courts pour chiens à poils courts
- d. Contacts longs pour chiens à poils longs



- a. Empf. Halsband
- b. Dummy Halsband
- c. Kontakte für normales Fell
- d. Lange Kontakte für langhaarige Hunde



- a. Collare attivo (contrassegnato da indicazioni stampate)
- b. Collare finto
- c. Sonda installate per pelo medio
- d. Sonda supplementari per pelo folto



- a. Correctie band (let op merk tekens)
- b. Dummy band
- c. Standaard stiften voor honden met kort tot middellang haar
- d. Lange stiften voor honden met lang haar



- a. Collar activo (flechas dibijadas)
- b. Collar pasivo
- c. Sonda pelo corto/medio
- d. Sonda pelo largo

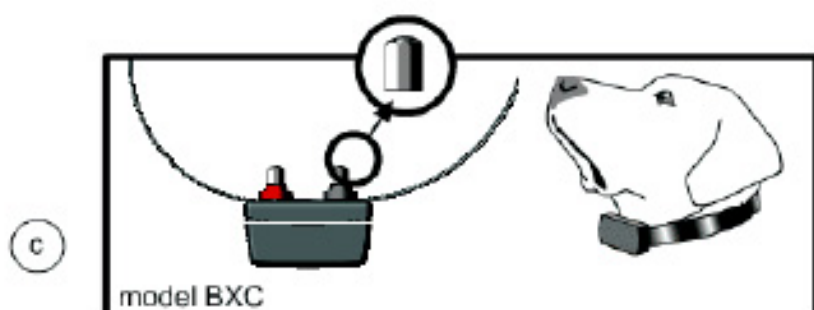

(c)

model BXC

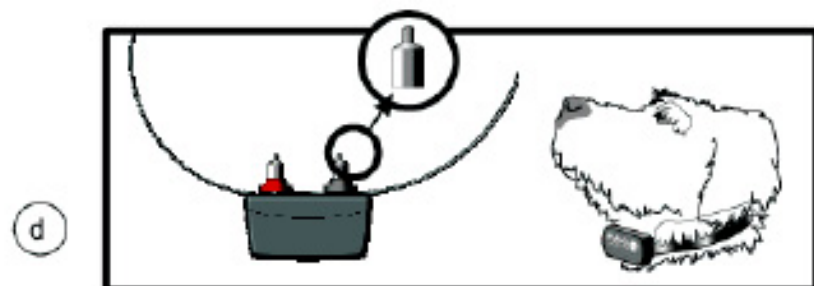

(d)

BXC MODEL

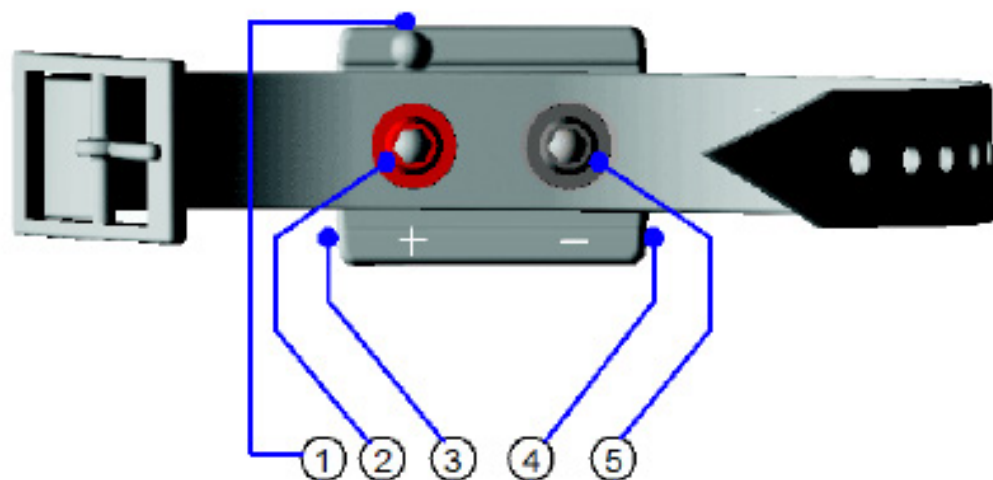

AXC MODEL

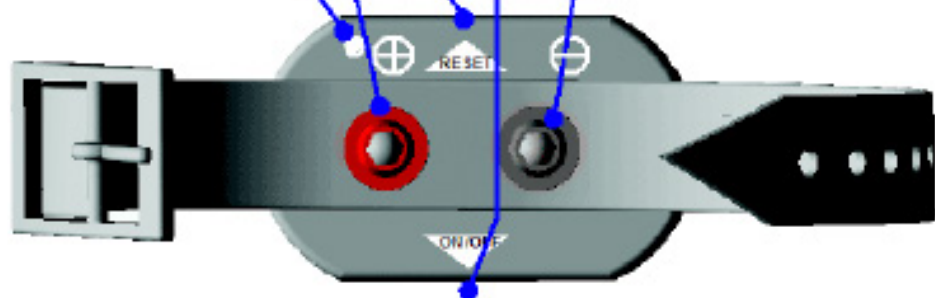

- A. Active Collar:
1. Status Lamp
 2. Positive Probe
 3. Reset contact point
 4. On/Off contact point
 5. Negative Probe



- A. Caractéristiques du collier de dressage
1. Diode de fonctionnement
 2. Contact positif
 3. Réinitialisation
 4. Marche / Arrêt
 5. Contact négatif



- A. Empf. Halsband
1. Status LED (Anzeigelampe)
 2. Positiver Kontakt
 3. Negativer Kontakt
 4. RESET Schaltpunkt
 5. ON/OFF Schaltpunkt



- A. Collare attivo
1. Led segnalatore di stato
 2. Polo positivo
 3. Punto di contatto RESET
 4. Punto di contatto ON/OFF
 6. Polo negativo



- A. Correctie band
1. Bedrijfsstoestand indicator (led)
 2. Positieve stift
 3. Contact punt voor resetten
 4. Contact punt voor aan/uit
 5. Negatieve stift



- A. Collar activo:
1. luz information
 2. Sonda positiva
 3. Punto contacto reajuste
 4. Punto de contacto encendido/apagado
 5. Sonda negativa



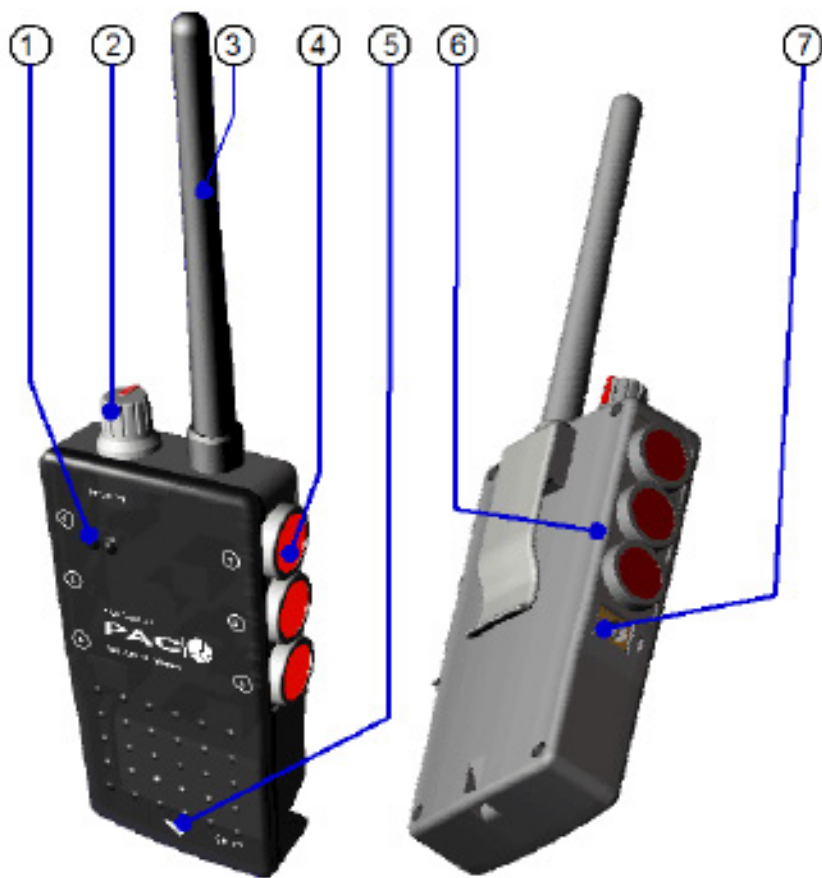

1. Battery Indicator LEDs (red and green)
2. Intensity Control
3. Antenna
4. Triggers (DXT3/6)
5. Collar activator
6. Triggers on DXT4 and DXT6 only
7. Recharging socket



1. Diodes (verte – rouge) de fonctionnement
2. Contrôle de l'intensité
3. Antenne
4. Boutons de commande
5. Activateur du collier
6. Uniquement modèles DXT4 et DXT6
7. Prise de rechargement



1. Status LED (Anzeigelampe). Rot und Grün
2. Stärkereglter
3. Antenne
4. Drücker
5. Schalterpunkt für das Halsband
6. Drücker allein für DXT4 und DXT6
7. Ladebuchse



1. Indicatore di livello batteria (Rosso e verde)
2. Selettore di intensita'
3. Antenna
4. Tasto di controllo
5. Area di attivazione dei collari
6. Tasti in dotazione solo ai modelli DXT4 e DXT6
7. Jack per la ricarica del trasmettitore



1. Batterij indicatie(rood&groen)
2. Intensiteit instelling
3. Antenne
4. Functie knoppen
5. Contact punt voor band activering
6. Alleen model DXT4 en DXT6
7. Aansluit punt voor opladen



1. Indicador de batería (rojo/verde)
2. Control de intensidad
3. Antena
4. Botones trigger
5. Zona de activación del collar
6. Solo en modelo DXT4/DXT6
7. Conexión recargador de batería





1. Plug Power Unit into Mains (3 pin version shipped for UK)
2. Plug DC jack into Charging Dock
3. Plug lead into Handset (if handset needs to be charged)
4. Plug Collar firmly into Charging Dock, with +ve probe to +ve socket
Collar will not charge if plugged in wrong way round
5. Press 'Set Timer' for full 16 hour charge
6. Position of Collar(s) and Handset on Charging Dock



1. Introduisez la prise du transfo dans une prise
2. Introduisez l'embout du transfo dans le boîtier de recharge
3. Introduisez l'embout du boîtier de recharge dans la télécommande
4. Posez le collier dans le boîtier de recharge (vérifiez la polarité ++)
5. Pressez le «SET TIMER» pour une charge de 16 heures
6. Position du ou des colliers et de la télécommande sur le chargeur



1. Adapter (Transformer) einstecken dann...
2. Ladegerät anschließen
3. Sender anschließen (wenn notwendig)
4. Halsband einstecken (Polaritäten +/- beachten)
5. SET TIMER drücken (automatische 16 Stunden Ladezeit)
6. Position von 2 Halsbänder und Sender



1. Inserire l'Alimentatore/Adattatore nella presa di corrente
2. Inserire il jack dell'Alimentatore/Adattatore nell'Unita' di ricarica
3. Inserire il jack dell'Unita' di Ricarica nel Radiocomando
4. Inserire i collari nell'Unita' di Ricarica avendo cura di rispettare le polarita'
5. Premere "Set Timer" per una ricarica di 16 ore
6. Posizione del/i collare/i e del radiocomando sull'Unita' di Ricarica



1. Steek de netspanning adapter in het stopcontact
2. Steek de dc plug in het laadstation
3. Steek de uitgaande aansluitkabel in de handset (optie)
4. Steek de band in het laadstation (let op polariteit)
5. Druk nu op "set timer", voor 16 uur laden
6. Positie van 1 of 2 banden in het laadstation



1. Conectar 'power unit' a la fuente
2. Conectar 'charging dock'
3. Conectar 'charging dock' al mando
4. Conectar collar al 'charging dock'
5. Pulsar botón 'set timer' Cargará durante 16 horas.
6. Posición del collar y el mando en el 'charging dock'

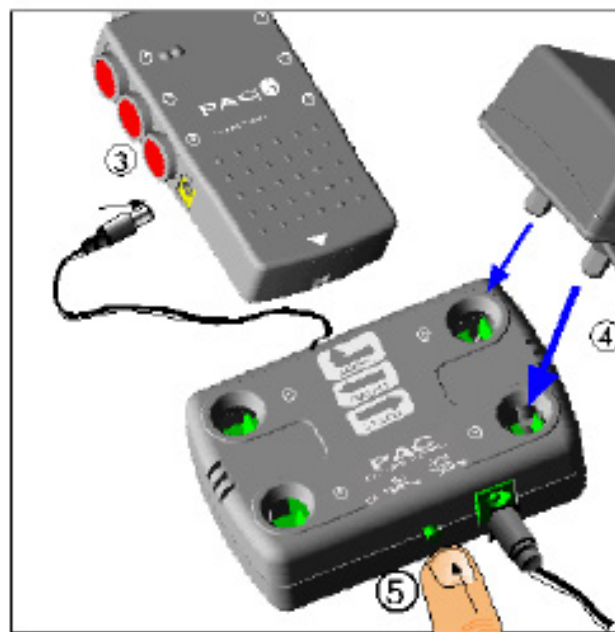

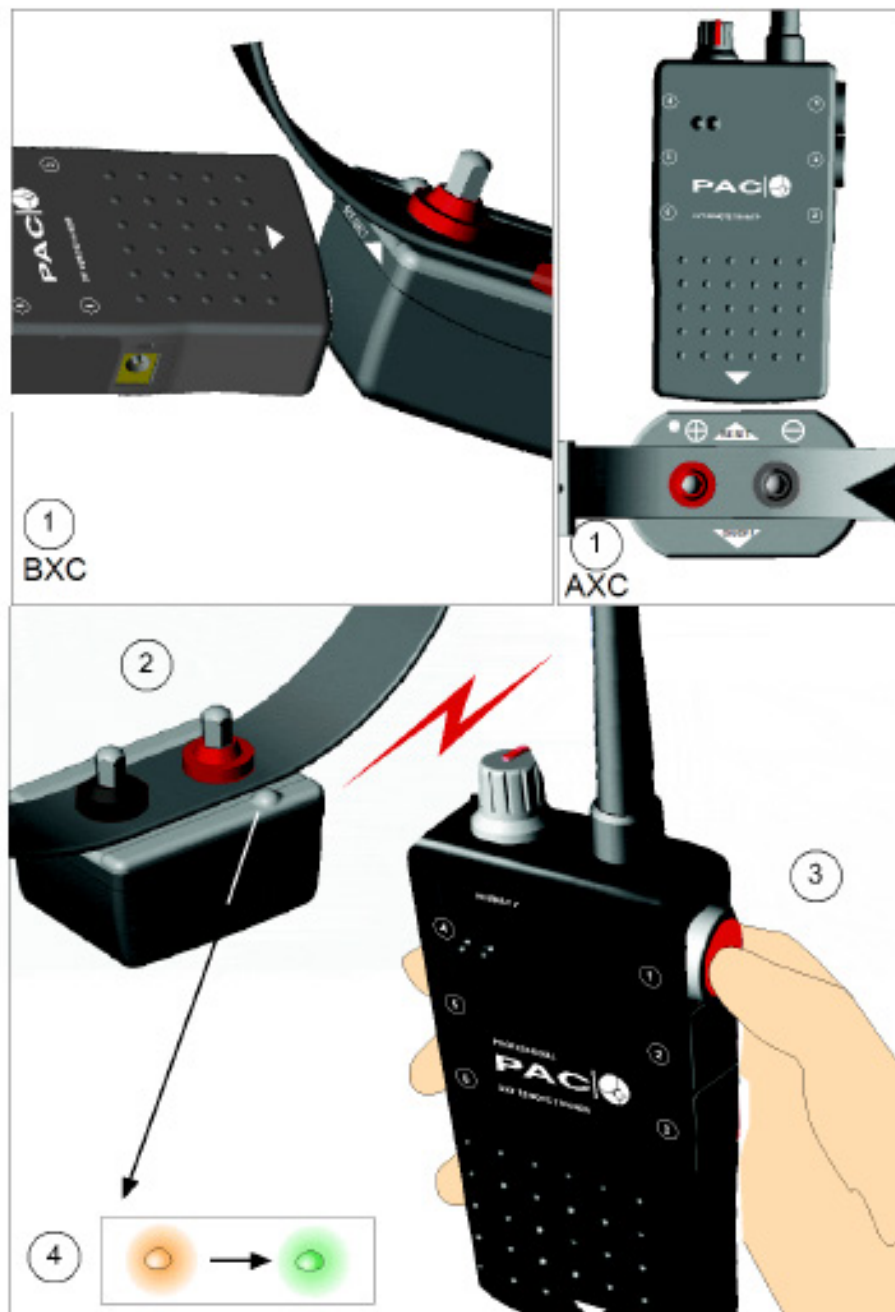

Match collar to handset trigger(s) using Reset operation

1. Bring the handset arrow into contact with the RESET arrow on the collar
2. Separate again, and the collar LED will fast flash orange
3. Press handset trigger briefly and it will send a 'matching' signal to the collar
4. Fast flashing orange changes to slow flashing green



Le collier doit être initialisé pour savoir sur quel bouton de commande il doit être programmé. Pour l'initialiser:

1. Portez le triangle blanc de la télécommande en contact avec le triangle «RESET» sur le collier
2. La diode du collier va se mettre à clignoter en orange
3. Pressez le bouton de la télécommande sur lequel vous voulez programmer votre collier
4. La diode du collier va se mettre à clignoter en vert (un clignotement par seconde)



1. Halten Sie den Sender mit dem unteren Teil wo der weiße Pfeil (Dreieck) ist kurz über den Empf. wo RESET steht
2. Nun sollte die Lampe am Empf. schnell rot bis gelblich leuchten.
3. Jetzt drücken Sie die Taste für den entsprechenden Empfänger (haben sie nur ein Empfänger dann ist es egal welche)
4. etzt blinkt die Lampe wieder normal grün und der Empf. ist eingeschaltet und die Frequenz abgestimmt



I collari devono essere resettati per assegnarli ad un determinato tasto di controllo. Per assegnare i collari ai tasti :

1. Mettere a contatto la freccia bianca sul radiocomando con la freccia bianca " RESET " sul collare ;
2. Sul collare si accendera' una luce arancione lampeggiante
3. Premere il tasto a cui si vuole assegnare il collare
4. Una volta assegnato un tasto al collare , il led su quest'ultimo comincera' a lampeggiare verde (un lampo al secondo)



Het resetten zorgt voor het juiste signaal tussen handset en band

1. Plaats de pijl aan de onderzijde van de handset tegen de RESET pijl op de band
2. De led op de band gaat oranje knipperen
3. Druk nu op functie toets 1 om handset en band af te stemmen
4. De led zal nu van overgaan van oranje naar groen en de functie toetsen zijn nu afgestemd op de band



Para emparejar el collar con el mando utilize la función de reajuste.

1. Acercar la flecha dibujada en las base del mando en contacto con la flecha de 'RESET' en el collar
2. Aparecerá una luz intermitente naranja
3. Pulse el botón trigger del mando para emparejar el collar al mando
4. La luz intermitente naranja cambiará á verde



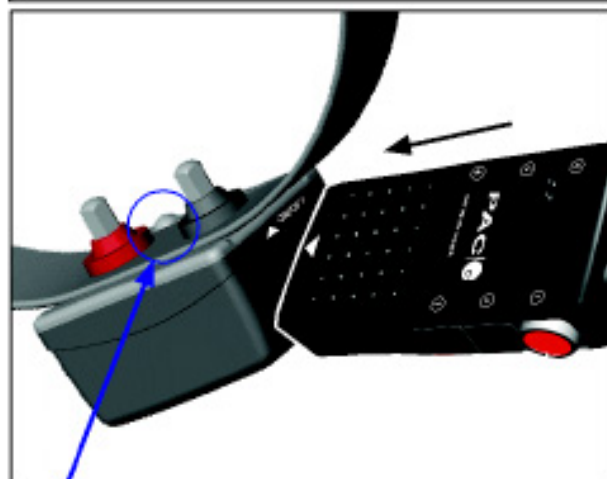
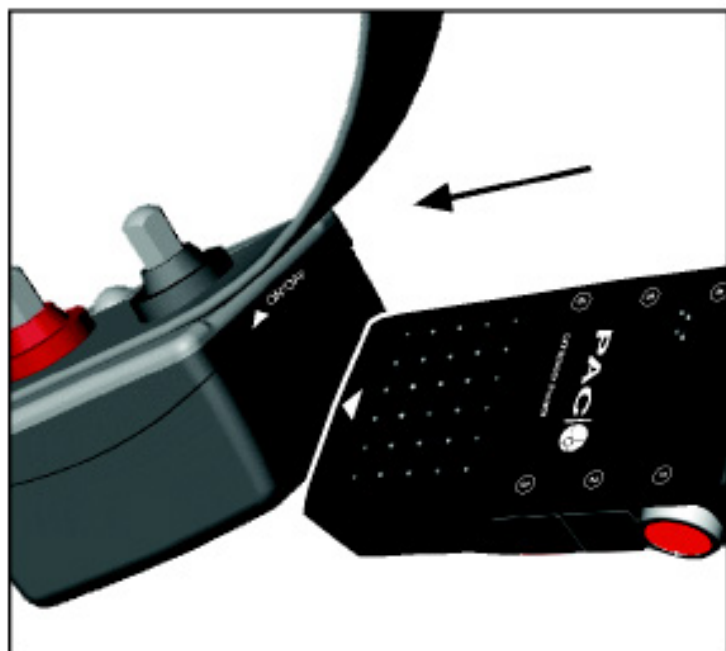

Turn collar on by bringing arrow at base of handset into close proximity with ON/OFF arrow on collar. A *beep* and green light will show status. Do the same to turn OFF the unit. A red light and *beep* will indicate action.



Pour mettre en marche le collier, posez le triangle de la télécommande sur le triangle «ON/OFF» du collier. Un bip et une diode verte vous indiqueront que le collier est en marche. Faites la même chose pour éteindre le collier. Un bip et une diode rouge vous indiqueront que le collier est à l'arrêt.



Am Sender befindet sich am unteren Teil ein weißer Pfeil (Dreieck) diesen halten Sie kurz über den Empf. wo ON/OFF steht, es ertönt ein Piepton und die LED leuchtet grün im 2 Sekunden-Takt, der Empf. ist hiermit angeschaltet. Zum Ausschalten den Vorgang wiederholen allerdings den Sender ca. 2-3 Sek. über den Empf. halten (LED leuchtet kurz rot dann ertönt ein Piepton und das Gerät schaltet sich ab).



Per accendere il collare mettere a contatto la freccia bianca sul radiocomando con la freccia bianca "ON/OFF" sul collare. Un "beep" e la luce verde accesa sul collare mostreranno l'avvenuta accensione. Per spegnere il collare eseguire il solito procedimento: un "beep" e la luce rossa avvertiranno dell'avvenuto spegnimento.





Schakel de band aan door pijl op de handset in contact te brengen met de ON/OFF pijl op de band. wacht op toon (piep) en groene led indicatie op de band. Een langzaam groen knipperende led geeft aan dat de band is ingeschakeld. Schakel de band uit op de zelfde manier. Wacht op toon (piep) en een rode led indicatie op de band. Led uit = band uit (of batterij leeg).





Active el collar acercando la flecha dibujada en la base del mando la flecha del collar. Oirá un tono y se encenderá la luz verde. Para apagarla repita la operación, oirá un tono y se encenderá la luz roja.





1. Insert the collar probes into the neon tester: press for stimulation: neon flashing proves stimulation. (NB neon does not flash during tone signals) 
2. Red + green shows battery OK, red only shows battery low.
3. Battery status red/orange/yellow = low.

1. Attachez chacune des pinces de la lampe test sur un des contacts du collier. Appuyez sur le bouton de la télécommande, la lampe test s'allumera.
2. Diodes indicatrices de charge de la télécommande. 
3. Diode indicateur de charge du collier.

1. Klemmen Sie die Neontestlampe an die Kontakte, um den Impuls (stärke) zu testen
2. Zustand LEDs der Senderbatterien (grün+rot = OK, nur rot = niedrig)
3. Zustand LEDs der Empfängerbatterien (grün=OK, rot= niedrig) 

1. Agganciare i morsetti del Neon Tester alle sonde del collare per Verificare l'effettivo funzionamento della stimolazione. Schiacciando il tasto di controllo relativo al collare in questione, il neon si illuminerà
2. Indicatore di stato della batteria del radiocomando;
3. Indicatore di stato della batteria del collare. 

1. Bevestig de clips van de testlamp aan de stifen van de band. de lamp moet gaan branden indien knop 1 wordt ingedrukt.
2. Batterij indicatie op de handset (groen + rood = ok, alleen rood = laag)
3. Batterij indicatie op de band (groen = ok, rood = laag) 

1. Coloque el 'comprobado neon' en el collar para comprobar la intensidad del estímulo
2. Indicador del estado de la batería del mando
3. Indicador del estado de la batería en el collar. 

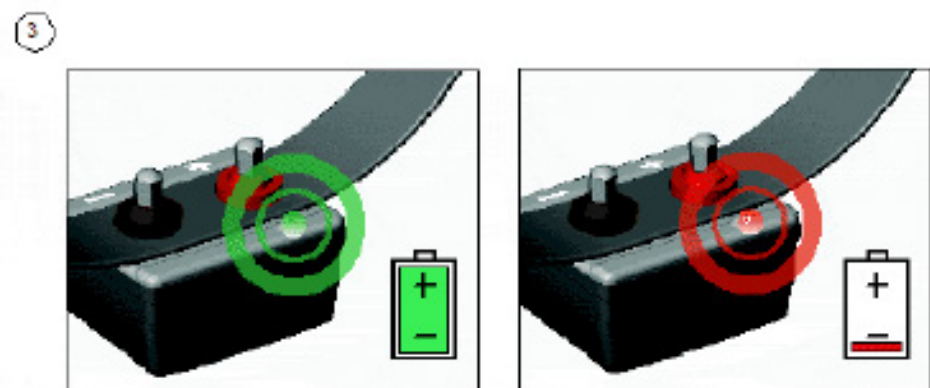
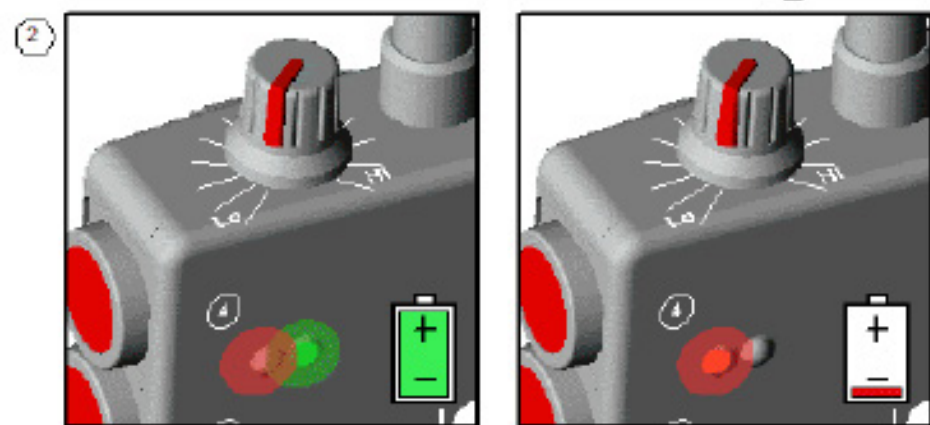
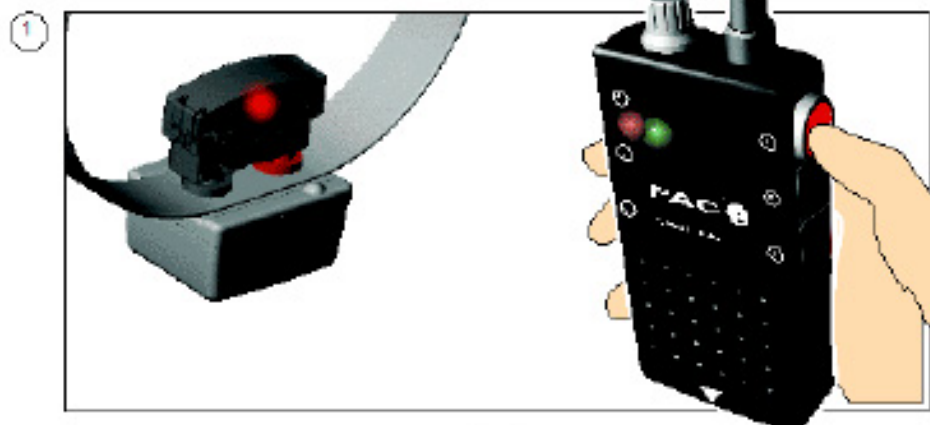

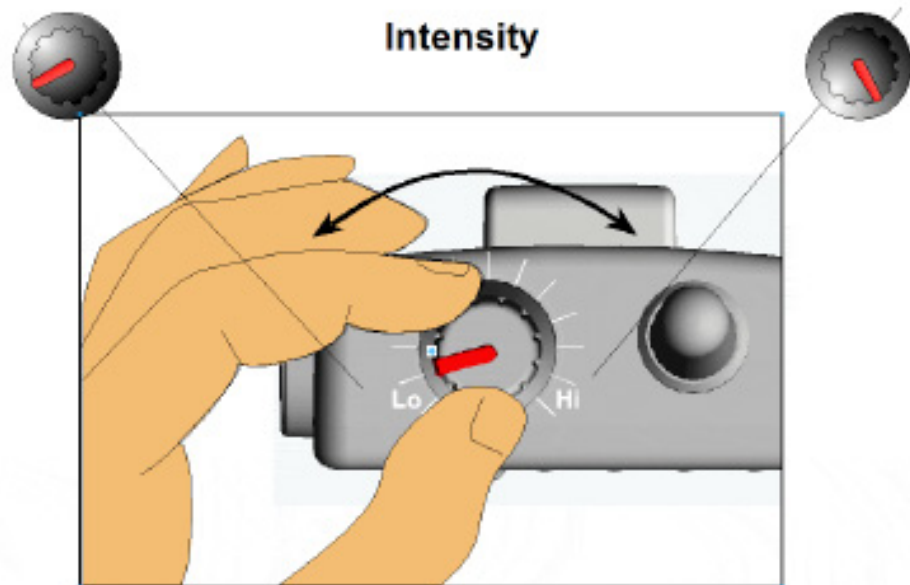
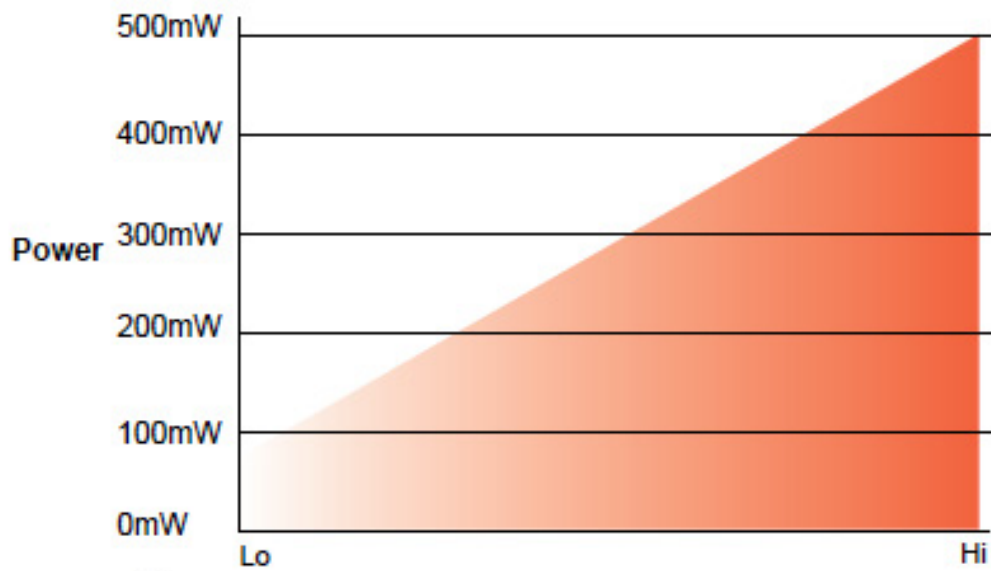

The collar stimulus can be increased in 64 smooth steps from 75mW up to the collar maximum (i.e. up to 500 mW on AXC collars)
 The control can have a tone only zone also, explained later.
 Diagram shows Intensity Control in dedicated mode, i.e. non-basic..



Le bouton de variation d'intensité fait évoluer celle-ci par pas régulier de 75mW jusqu'à 500mW.
 Le bouton de modification d'intensité peut aussi avoir une position son uniquement. (voir plus loin)



Der Spannungsregler hat 64 Stufen für den Empfänger und ist dadurch nahezu Stufenlos verstellbar.



Il selettore di intensita' lavora con continuita' da 75mW fino a 500mW.
 Il selettore permette anche l'utilizzo di una stimolazione solo sonora , opzione di cui parleremo piu' avanti.



De instelling van de intensiviteit verloopt met kleine stappen van 75 mw tot 500 mw. Indien alleen met correctie toon gewerkt wordt de schakelaar op de laagste stand zetten (zie p12)



El control de intensidad del estímulo actúa gradualmente desde 75 mw a 500mw



Mode B

Mode E/P

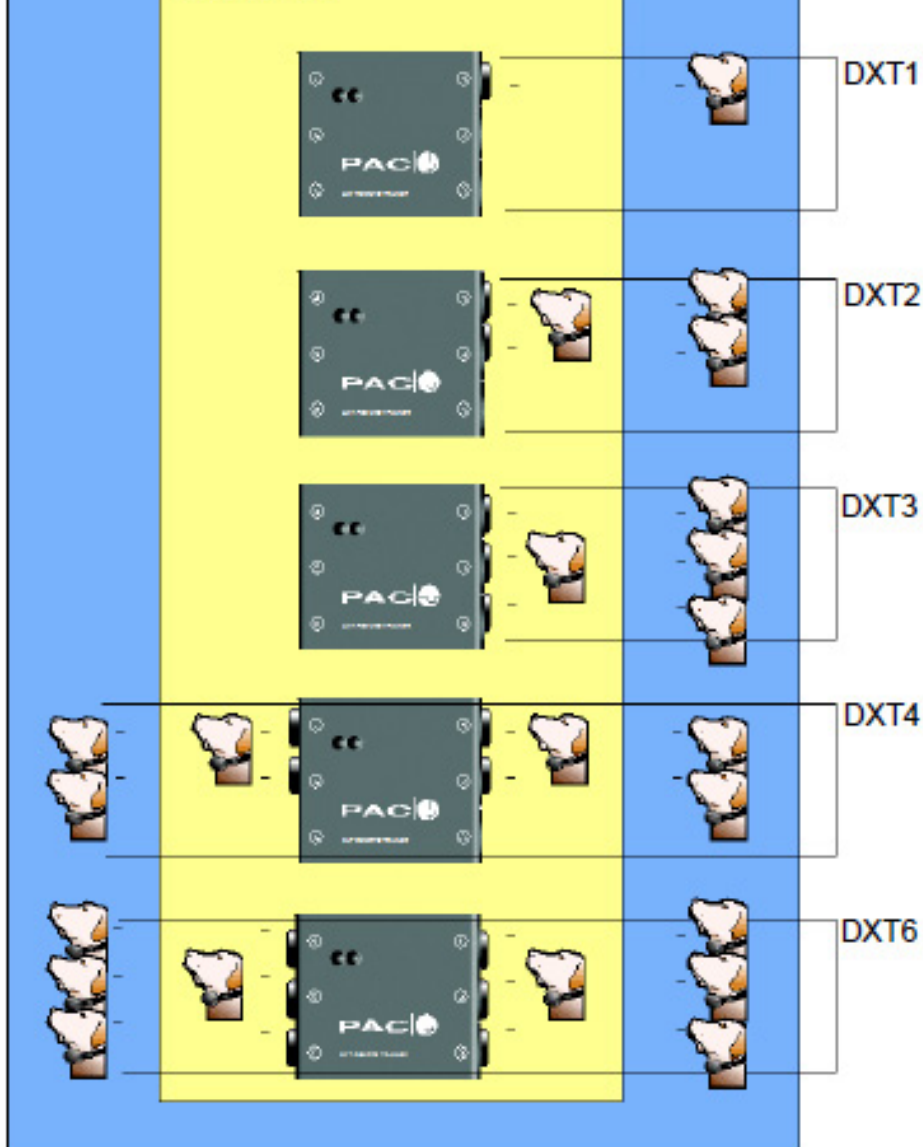

Depending on your handset model, choose the desired operating mode.

Mode B: BASIC: Each trigger is multifunction and controls 1 dog -see page 12.
Mode E/P: Enhanced/Professional Mode: Each trigger is dedicated to one function- see page 13



Identifiez d'abord le type de modèle DXT que vous possédez ensuite choisissez le mode;

Mode B: Mode de Base, chaque bouton pilote son propre collier. (voir page 12)
Mode E/P: Mode Professionnel, chaque bouton possède sa propre fonction pour un ou deux colliers. (voir page 13)



Abhängig vom Modell, können bis zu 6 Empfänger vom Sender angesteuert werden.
Mode B: Grundlegend Betriebsart: Jeder Drücker kann bis zu 3 Funktionen kontrollieren – pro jedem Halsband (Hund) – siehe p12.

Mode E/P: Erweitere- u profi Betriebsarten: Jeder Drücker bekommt nur eine Funktion – 2 oder 3 drücker pro jedem Halsband (Hund) – siehe p13.



Per cominciare identifica il tipo di modello DXT che hai e la tua modalita' operativa preferita.

Modalita' B : Modalita' Base in cui ad ogni tasto e' assegnato un singolo collare. I tasti lavorano tutti con la stessa funzione. Vedere pag. 12
Modalita' E/P : Modalita' Professionale. Ad ogni tasto e' assegnata una particolare funzione per controllare uno o max. due cani . Vedere pag. 13 .



Afhankelijk van het type handset kunt u een keus maken uit de volgende instellingen:
Stand B (basis): elke knop is multifunctioneel en werkt met maximaal 1 hond (p12)
Stand E/P (uitgebreid/professioneel): elke knop heeft een vaste functie (p13)



Dependiendo del modelo del mundo, eliga el modo de aparición deseado
Modo B: Básico: cada botón trigger es multifuncional y controla un perro (pag.12)
Mode E/P: Modo profesional, cada botón trigger controla una función (pag 13)



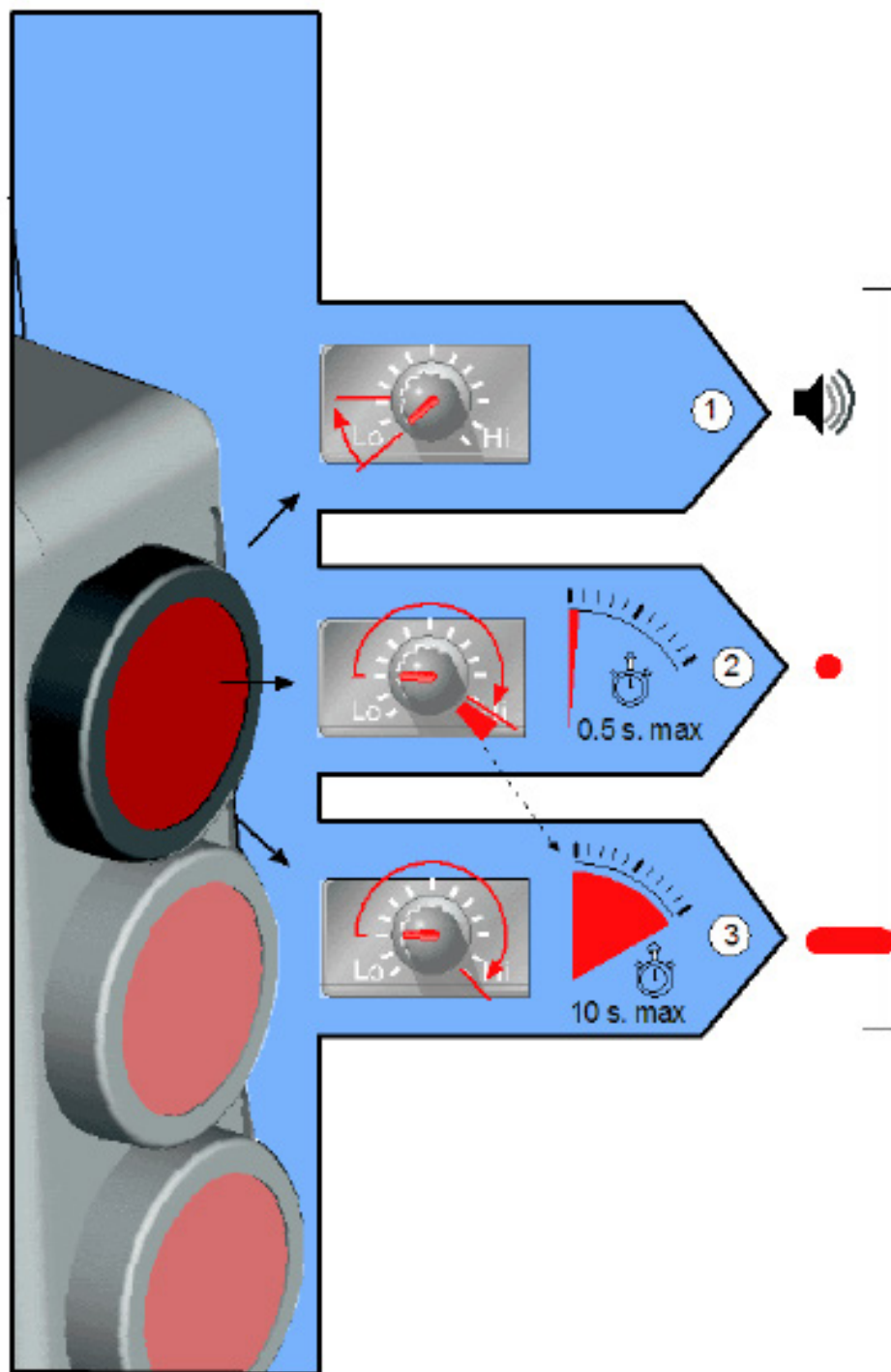

Each Handset trigger normally shares two functions and is assigned to an individual collar:

1. Collar Tone (at Lo Intensity level) and either
2. Momentary Collar Stimulation (changing to Continuous at Hi) or
3. Continuous Collar Stimulation



See pages 14 and 15 for more information

Chaque bouton pilote son propre collier. Chaque bouton peut avoir 2 fonctions, dépendant de la position du bouton de variation d'intensité.

1. Uniquement son (au degré d'intensité minimal)
2. Impulsion momentanée (1/4 de seconde) avec impulsion continue sur la position HI. ou
3. Impulsion continue



Les pages 14 et 15 vous expliquent comment régler votre télécommande pour chacun de ces modes.

Jeder Drücker kann bis zu 2 Funktionen an den Empfänger Senden.

1. Nur Ton bei einem Halsband oder bei zwei (oder mehr Halsbändern) nur Ton bei den ersten zwei Teilstrichen an dem Stärkereglern danach Strafe und entweder
2. Kurzimpuls oder
3. Langimpuls



Ogni tasto di controllo del radiocomando gestisce un singolo collare. Ogni tasto può gestire il collare in 2 differenti modi a seconda della posizione in cui è posto il selettore di intensità:

1. Suono (a fianco e' mostrata l'area di suono)
2. Stimolazione momentanea (continua in posizione Hi)
3. Stimolazione continua



Le pagg. 14 e 15 spiegano come impostare il radiocomando PAC per ottenere questi modi operativi.

Elke knop kan 2 verschillende functies uitvoeren voor een individuele band.

1. Alleen toon (op laagste intensiviteit instelling) en of
2. Puls correctie (continue op hoogste stand) of
3. Continue correctie



Zie pagina 14 & 15 voor meer informatie

Cada botón trigger del mando comparte hasta 2 funciones y es asignado a un solo collar:

1. Tono del collar (baja intensidad)
2. Estimulación momentánea (alta intensidad)
3. Estimulación continua



Vea paginas 13 y 14 para mas información

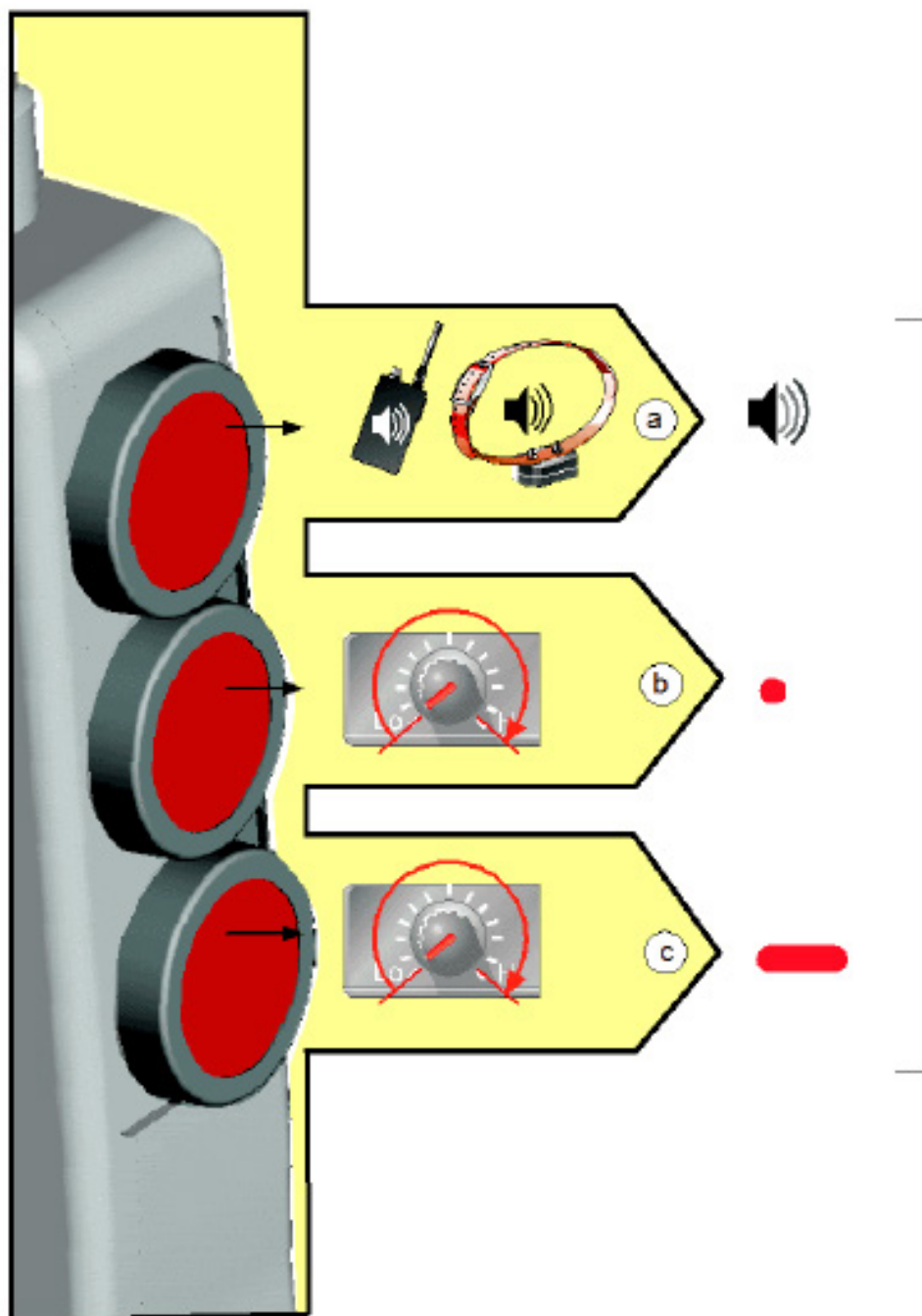

- a. DXT2, 3, 4 & 6 - Trigger(s) 1 / 4 → tone warning
- b. DXT2, 3, 4 & 6 - Trigger(s) 2 / 5 → momentary or...
- b. DXT2 / 4 (only) - Trigger(s) 2 / 5 → continuous
- c. DXT3 / 6 - Trigger(s) 3 / 6 → continuous



- a. DXT2, 3, 4 & 6 - Bouton(s) 1 / 4 → tone warning
- b. DXT2, 3, 4 & 6 - Bouton(s) 2 / 5 → momentary or...
- b. DXT2 / 4 (only) - Bouton(s) 2 / 5 → continuous
- c. DXT3 / 6 - Bouton(s) 3 / 6 → continuous



- a. DXT2, 3, 4 & 6 - Drücker(s) 1 / 4 → Ton als Warnung vom Empfänger
- b. DXT2, 3, 4 & 6 - Drücker(s) 2 / 5 → kurzimpuls...
- b. DXT2 / 4 (only) - Drücker(s) 2 / 5 → langimpuls
- c. DXT3 / 6 - Drücker(s) 3 / 6 → langimpuls



- a. DXT2, 3, 4 & 6 - Tasto 1 / 4 → suono sul collare
- b. DXT2, 3, 4 & 6 - Tasto 2 / 5 → intermittente...
- b. DXT2 / 4 (only) - Tasto 2 / 5 → continua
- c. DXT3 / 6 - Tasto 3 / 6 → continua



- a. DXT2, 3, 4 & 6 - Knoppen 1 / 4 → toon op band
- b. DXT2, 3, 4 & 6 - Knoppen 2 / 5 → puls correctie...
- b. DXT2 / 4 (only) - Knoppen 2 / 5 → continue correctie
- c. DXT3 / 6 - Knoppen 3 / 6 → continue correctie



- a. DXT2, 3, 4 & 6 - Trigger(s) 1 / 4 → tono de advertencia del collar
- b. DXT2, 3, 4 & 6 - Trigger(s) 2 / 5 → momentáneo...
- b. DXT2 / 4 (only) - Trigger(s) 2 / 5 → momentáneo
- c. DXT3 / 6 - Trigger(s) 3 / 6 → continuo



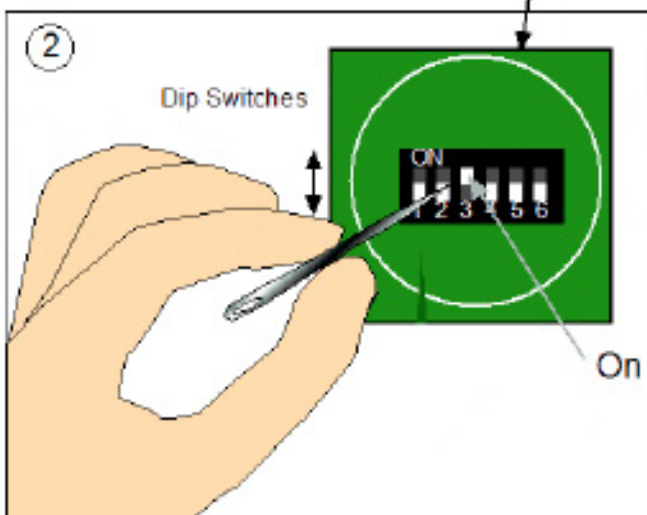
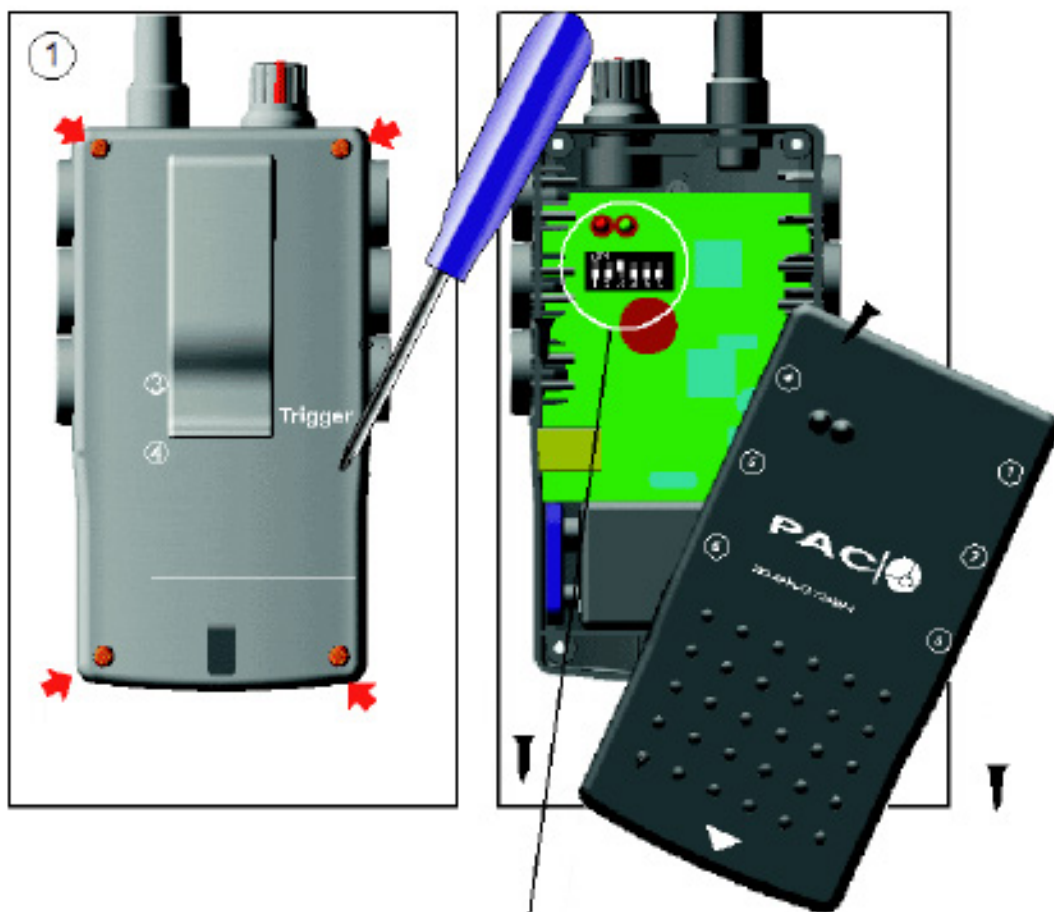

1. Undo screws to remove the cover and expose the Dip Switches. Each switch can turn on or off a function.
2. Use a small screwdriver/large needle to slide the switches, referring to guide on pages 15 and 16.
3. Shows the switch (#3) for disabling the handset confirmation buzzer. Other remaining switches concern collar unit functions.



Configuration: Modification grâce aux interrupteurs La télécommande doit maintenant être configurée en fonction du mode de fonctionnement choisi.

1. Otez le couvercle de la télécommande pour découvrir les interrupteurs. Chaque interrupteur peut activer ou désactiver une fonction.
2. Utilisez un objet pointu pour modifier la position des interrupteurs. (voir page 15 et 16 pour configuration)
3. Fig. a :vous montre comment désactiver le son de votre télécommande



1. Sie müssen die Deckel entfernen um die Mini-Schalter bedienen zu können.
2. Mit kleinem Schraubenzieher oder Nadel können Sie die Schalter in die gewünschte Stellung bringen (siehe pp 15&16)
3. Mit diesem Schalter können Sie den Senderton ausschalten. Mit allen andere Schaltern ändern sie die Funktionen des Empfängers.



Il radiocomando deve essere ora impostato per rispondere alle tue esigenze.

1. Rimuovere la parte superiore del radiocomando per accedere agli interruttori di selezione. Ogni interruttore attiva o disattiva una funzione.
2. Usare un piccolo cacciavite a taglio per agire sugli interruttori , facendo riferimento alle indicazioni di pagg. 15 e 16.
3. mostra l'interruttore per disattivare il suono sul radiocomando. Gli altri interruttori selezionano le varie funzioni dei collari.



Functies instellen : toegang tot de micro schakelaars

1. Verwijder het deksel om bij de micro schakelaars te komen
2. Gebruik een kleine schroevendraaier of een grote naald om de schakelaars in de juiste positie te zetten (zie p15&16)
3. Schakelaar 3 regelt toon indicatie op de handset, alle andere schakelaars hebben betrekking op functies van de band.





1. Abra la cubierta, en su interior encontrará los interruptores DIP switches (fig.2) Cada interruptor enciende o apaga una función.
2. Utilice un objeto puntiagudo para encender o apagar los interruptores (Especificado en página 15 y 16 de la guía)
3. La figura número 3 indica como encender/apagar el tono de advertencia del mundo.

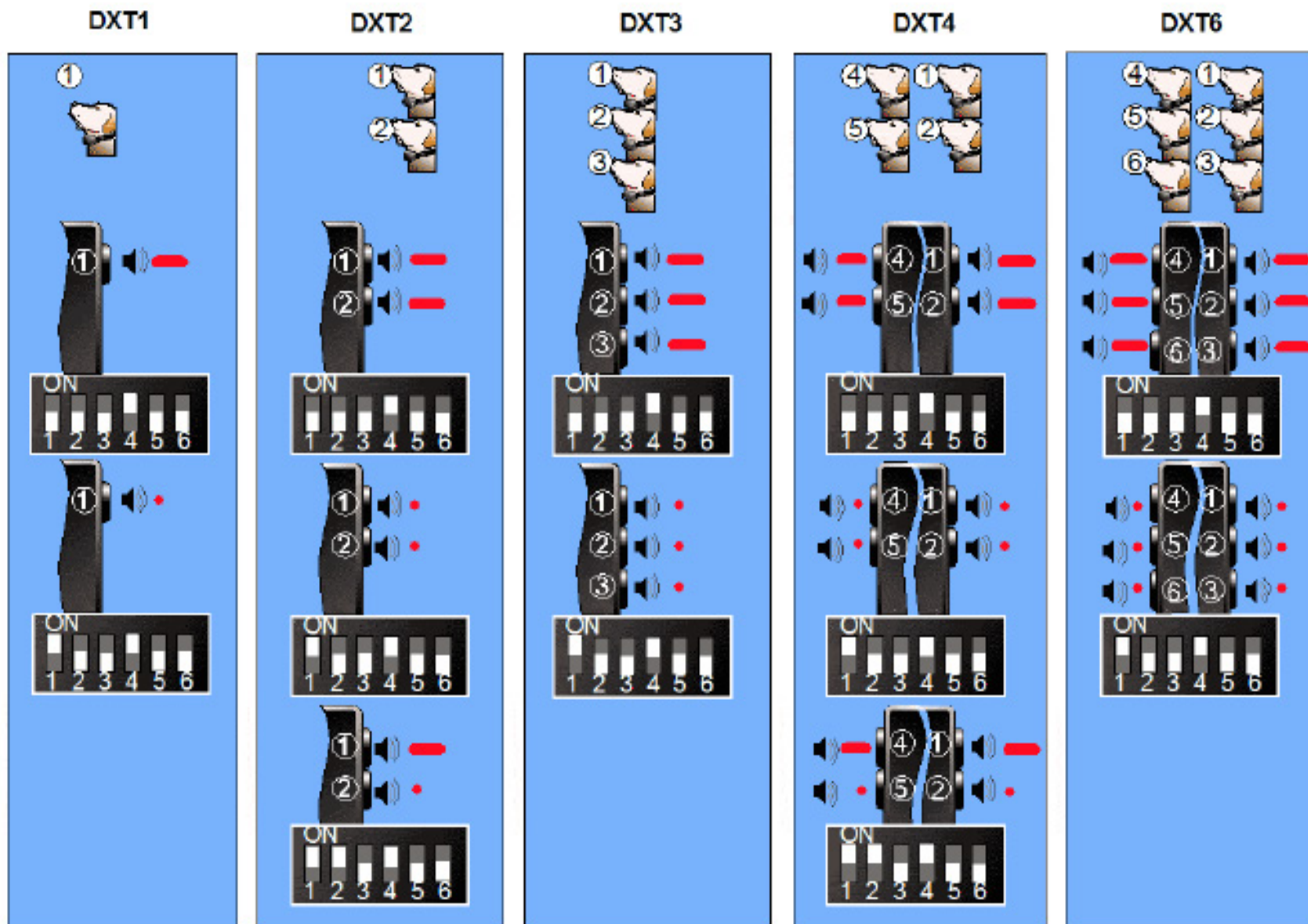



Mode B assigns a trigger for each Training Collar depending on Intensity Control Settings.

Collar Tone Warning: 

Momentary Stimulus: 

Continuous Stimulus: 



Le Mode B dédie à chaque bouton de commande un collier.

Uniquement son impulsion momentanée 

impulsion continue 





In dieser Betriebsart können sie den Empfänger verschiedene Funktionen mit einem Drücker zuweisen.

Tonwarnung 

kurz Impuls 

lang Impuls 



Modalita' B assegna un singolo collare ad un singolo tasto di controllo.

Suono 

Tipo di stimolazione:

Momentanea 

Continua 



Schakelaar instelling: stand B
Stand B kent aan iedere knop een band toe (hond)

Toon waarschuwing 

Puls correctie 

Continue correctie 



Modo B: Asigna un botón trigger para cada collar de entrenamiento.

Tono del collar 

Estímulo momentáneo 

Estímulo Continuo 



Mode E/P
(Enhanced/
Professional
Mode)

DXT2 Enhanced

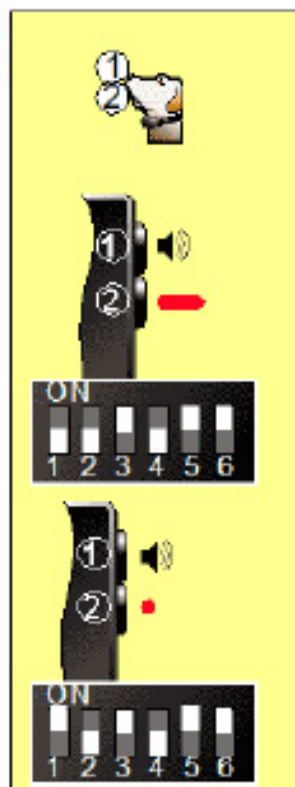

DXT3 Professional

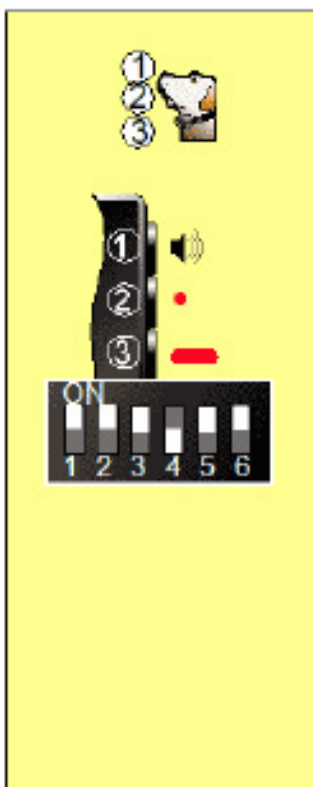

DXT4 Enhanced

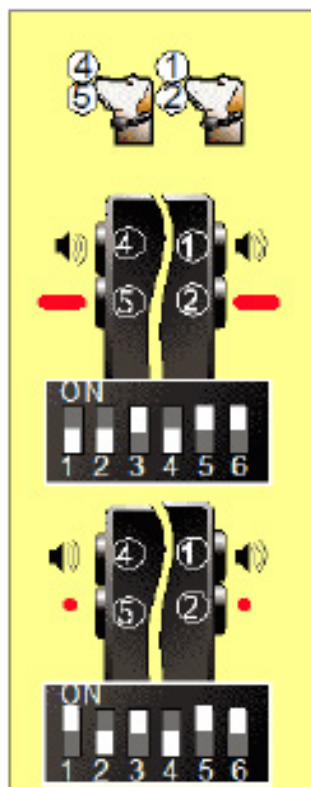

DXT6 Professional

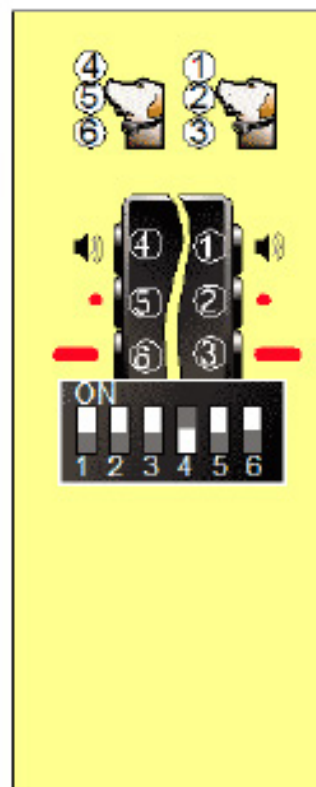

Mode E/P&H: Dedicated Function per trigger

Collar Tone Warning:

Momentary Stimulus:

Continuous Stimulus:



Mode H: Hybrid function for DXT2 & DXT4 only

Le Mode E/P dédie une fonction particulière

Uniquement son

Impulsion momentanée

Impulsion continue

Le Mode H (hybride) combine les fonction des boutons de commande entre les Mode B et Mode E/P.



Betriebsarten E/P: Jeder Drücker hat nur eine Funktion zugeordnet

Tonwarnung

Kurz Impuls

Lang Impuls

Betriebsart H: Hybrid Funktion - nur für DXT2,DXT4



Modalita' E/P : funzioni dedicate per ogni singolo tasto di controllo.

Suono

Tipo di stimolazione:

Momentanea

Continua

Modalita' H : (ibrida) e' una combinazione di funzioni tra la modalita' B e la modalita' E/P



Mode H
(hybrid)

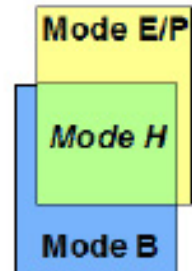

Schakelaar instelling: stand E/P (&H)

Toon waarschuwing

Puls correctie

Continue correctie

Stand HE: combinatie stand (geld alleen voor DXT2 & DXT4)



Modo E/P: asigna una función a cada trigger

Tono del collar

Estímulo momentáneo

Estímulo Continuo

Modo H

Combinación de funciones (solo para modelos DXT2 y AXT4)



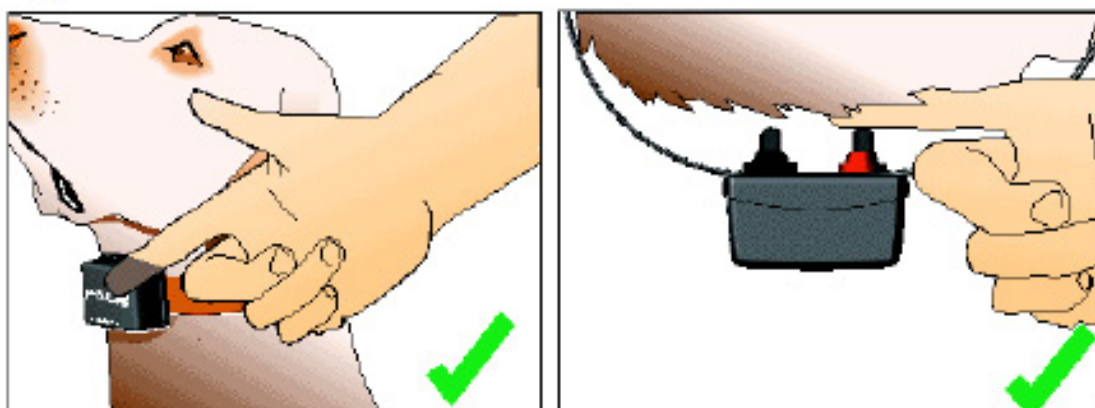

① +



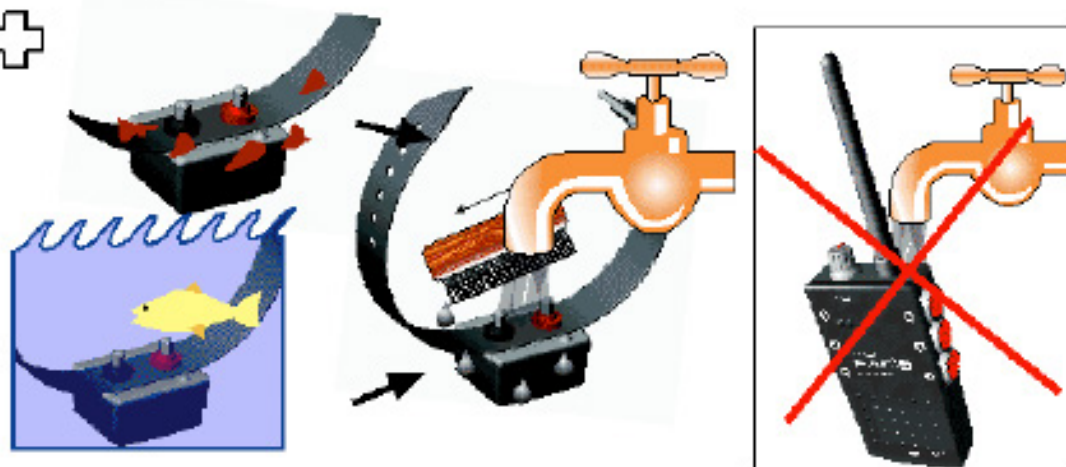

② +





1. Ensure collar is positioned correctly on narrowest part of neck. One finger should just be able to fit between each probe and the dog's neck to ensure a snug fit. Skin Irritation-Inspect the dog daily during collar use. A loose collar is a common cause of mis-function. 
2. If soiled or exposed to salt water, wash with freshwater and a brush.

1. Quand vous installez le collier au cou de votre chien, il doit toujours être possible de glisser un doigt entre les contacts et le cou du chien. Assurez vous que le collier est bien positionné au niveau du cou. Lorsque le chien porte le collier, vérifiez quotidiennement son cou pour éviter d'éventuelles irritations. La perte d'un collier n'est pas couverte par la garantie. 
2. Si votre collier est sale ou a été mis dans de l'eau salée, nettoyez le avec l'eau claire avec une brosse.

1. Vergewissern sie sich daß das Halsband richtig anliegt, ist es zu locker kann der Trainer nicht richtig arbeiten. Um Hautirritationen zu vermeiden beschränken sie den gebrauch auf das nötigste und kontrollieren Sie regelmäßig die Kontaktstellen. 
2. Säubern sie den Empfänger einfach mit sauberen wasser Vermeiden sie den Kontakt mit seewasser. Der Sender darf nur mit einem feuchten Tuch gereinigt werden.

1. Per un giusto posizionamento del collare , si consiglia di allacciarlo in modo che tra le sonde ed il collo del cane passi un dito. Assicurarsi che il collare sia posizionato correttamente sul collo. Controllare durante l'uso del collare il comparire di eventuali irritazioni sul collo del cane . Molto spesso queste sono causate da un collare troppo largo. 
2. Per pulire il collare o in caso di contatto con acqua salata , lavare quest'ultimo con acqua corrente ed una spazzola

1. Verzeker u ervan dat de band op de juiste plaats zit een vinger moet net tussen de stiften en de nek passen. Huid irritatie: Inspecteer de huid van de hond dagelijks tijdens de trainingen. Een te losse band is vaak de oorzaak van huid irritatie. 
2. Als de band vervuult is of in aanraking is geweest met zout water dan de band afspoelen met schoon water en een borstel 

1. Asegurese de que el collar está colocado corectamente en el cuello del animal. Debe haber un dedo de holgura entre el collar y el cuello. Irritación de la piel-insepcione diariamente el cuello del perro mientras el producto sea usado. Es normal que el collar ceda, cuando esto ocurra, vuelva a ajustarlo. 
2. Para limpiarlo use un paño húmedo.

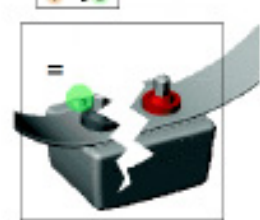
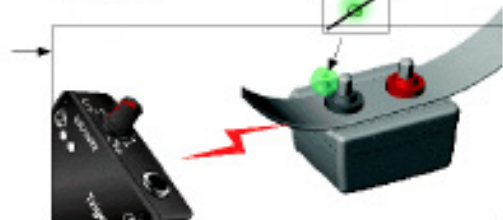
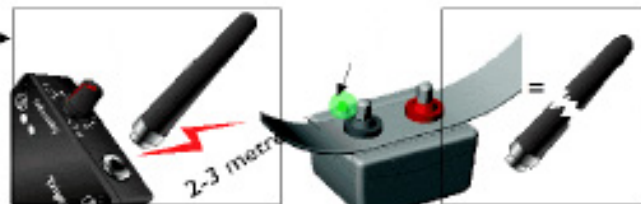
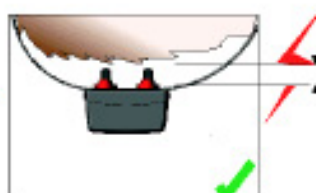
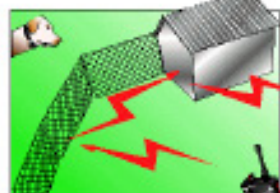
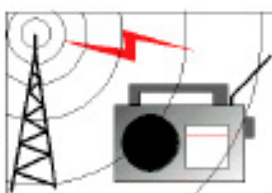

- a. Temporary radio interference: Try later or try another location
- b. Metal fencing/buildings are shielding signal: try elsewhere
- c. Collar strap too loose: Tighten strap
- d. Antenna failure? Handset should still work 2-3 metres away. Confirm if handset is OK. Order a replacement antenna
- e. Collar failure? Try RESET procedure and/or test as in (d) above.



- a. Interférence radio: attendez un instant ou essayez ailleurs
- b. Les clôtures métalliques ou certains immeubles peuvent faire ricocher les ondes.
- c. Un collier pas assez serré. Réajustez le collier.
- d. Antenne endommagée: faites un test sans antenne, si la portée sans antenne est de 2 à 3 mètres, commandez une nouvelle antenne chez votre fournisseur.
- e. Pas de communication entre le collier et la télécommande: ré-initialisez le collier et refaites le test. Si le collier continue à ne pas réagir, retournez le chez votre fournisseur.



- a. Verübergehend Funkstörung: Später oder auf einem anderen Gelände probieren.
- b. Metalle Zäune/Gebäude abschirmen: auf einem anderen Gelände probieren.
- c. Halsband zu los: fester machen (siehe p17).
- d. Antennen Fehler?: Probieren sie es ohne Antenne dann haben sie höchstens 2-4m Reichweite: Wenn der Sender OK ist - neue Antenne kaufen.
- e. Halsband Empfängerfehler?: Probieren sie RESET (siehe p7)



- a. Temporanee interferenze radio: aspettare un attimo o cambiare luogo;
- b. Reti metalliche o edifici che si interpongono tra il radiocomando ed il collare;
- c. Collare troppo largo. Stringere il collare sino ad una giusta posizione;
- d. Rottura dell'antenna di trasmissione. Provare il radiocomando senza antenna ad una distanza di 2/3 metri per averne la conferma. Ordinare una antenna sostitutiva. Mancata ricezione da parte del collare.
- e. Sintonizzare nuovamente il collare col radiocomando e fare un test come al punto d. Se il collare continua a non funzionare rivolgersi al centro assistenza.



- a. Aanwezigheid van stoorzender: probeer later of op andere locatie
- b. Metalen hekken of gebouwen beïnvloeden het signaal : probeer een andere locatie
- c. Band te los? : riem strakker stellen.
- d. Geen afstand bereik? Antenne stuk? : test zonder antenne op een afstand van 2 tot 3 meter. Indien dit geen storing geeft, vervang dan de antenne.
- e. Ontvangst probleem?: voer reset procedure uit en /of de test onder d (antenne).



- a. Interferencia de radio: Inténtelo pasados unos minutos o en otro lugar
- b. Evite el uso cesa de construcciones metálicas
- c. Si el collar ceica vuelva a ajustarlo
- d. Fallos en la antena: pruebe sin la antena a una distancia de 2 o 3 metros, si el mando emite señal, contacte con el distribuidor para reemplazarla
- e. I collar no recibe señal. Reajuste el collar (pag.7) o proceda como en fallos en la antena (d)



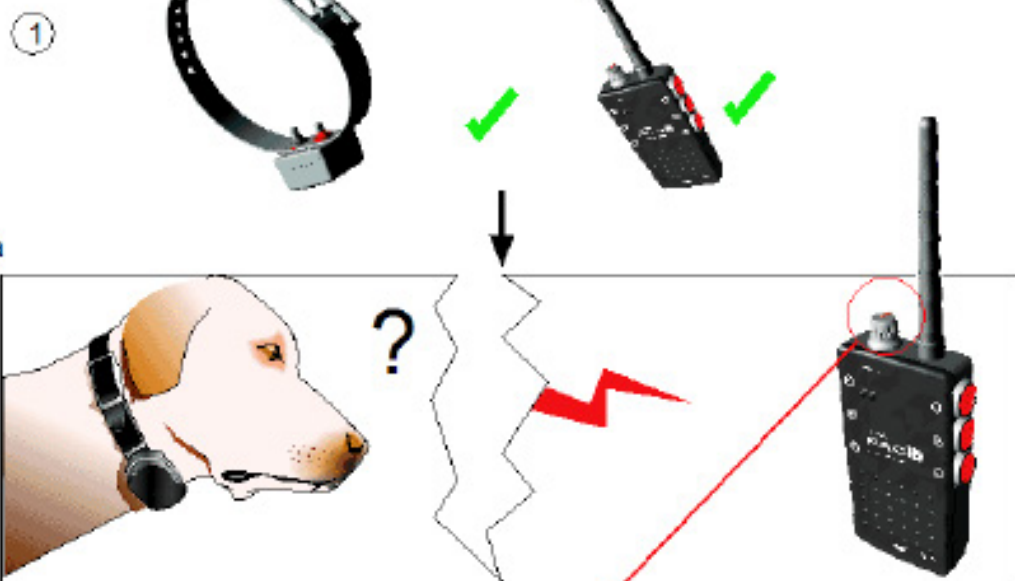

a



b

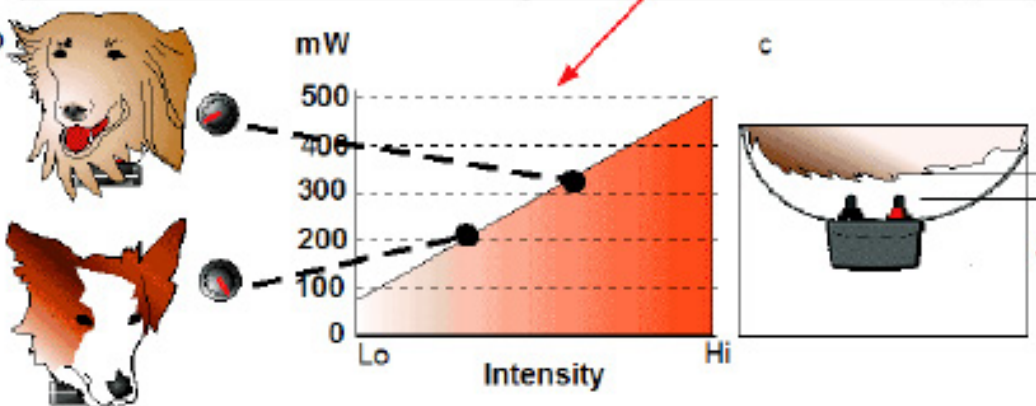

c

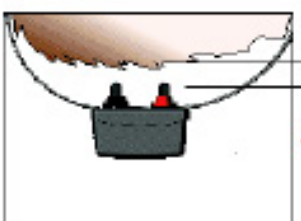

②

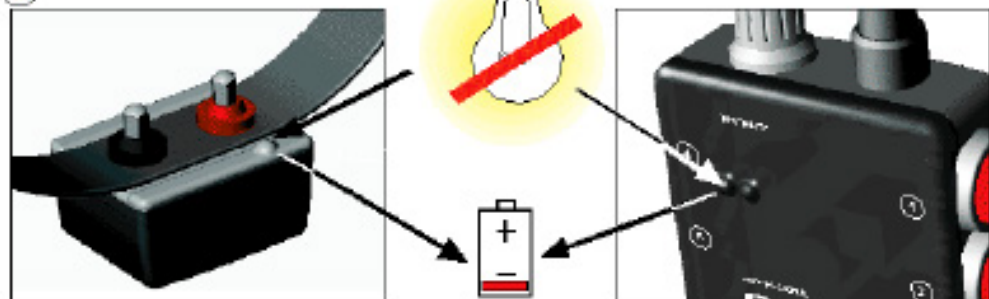

1. Collar Appears OK (LED flashes green) but no reaction from dog:

- Incorrect code?-Try RESET (p7).
- Intensity not high enough? Try gradual increase (p10)
- Collar too loose? Tighten (p17)



2.LED's not illuminating on collar or transmitter?

Possible Cause and solution: Batteries fully discharged. Full charge for 16 hours.

1. Le collier semble fonctionner (la diode clignote en vert) mais aucune réaction du chien. Les causes possibles sont les suivantes:

- une mauvaise longueur d'onde. Voir page 7
- le bouton d'intensité n'est pas assez élevé; Augmentez-le pas par pas jusqu'à ce que le chien réagisse.
- La sangle du collier est trop lâche. Réajustez-la.



2. La diode du collier ne s'allume pas. Il est possible que votre batterie soit déchargée, rechargez-la durant 17 heures.

1.Halsband sieht gut aus (LED blinkt schneller grün als knopf gedrückt wurde):

- Fehlerhafte Verbindung – probiere RESET (siehe p7).
- Spannung nicht stark genug – allmählich zunehmend verstärken (siehe p10)
- Halsband zu los: Fester machen (siehe p17)



2. Keine LED lichte auf Halsband oder Sender: Batterien völlig entladen?:
Wiederladen – 17 Stunden.

1. Il collare sembra funzionare (il led lampeggia verde), ma il cane non ha reazioni. Possibili cause e soluzioni :

- errata sincronizzazione tra collare e radiocomando. Vedi pag. 7
- intensità di stimolazione non adeguata al tipo di cane. Aumentare gradualmente sino a che non si ha una reazione da parte del cane;
- il collare e' troppo largo. Stringere sino alla giusta posizione.



2. Se il LED sul collare non si illumina , probabilmente la batteria e' completamente scarica. Caricare il collare per 17 ore.

1.Band lijkt goed(led knippert groen)maar geen reactie van de hond:

- Band en handset niet goed op elkaar afgestemd?:probeer resetten(p7)
- Intensiviteit niet hoog genoeg?: probeer stapsgewijs verhogen.(p10)
- Band te los?: strakker stellen (p17)



2.Led's branden niet?(op band of handset) : probeer 17 uur laden.

1. Si el collar funciona (luz verde intermitente encendida) pero el perro no reacciona:

- codigo incorrecto? Pruebe reajustar el collar (pag.7)
- Intensidad no suficiente? Auméntela gradualmente (pag.10)
- collar con demasiada holgura? Ajustelo de nuevo (pag 17)



2. No funcionamiento de la luz verde en el collar o en el transmisor?:

Posiblemente las baterías esten descargadas, recárguelas durante 17 horas.

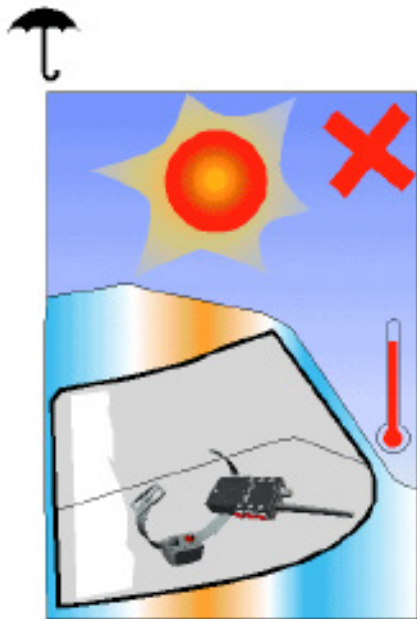
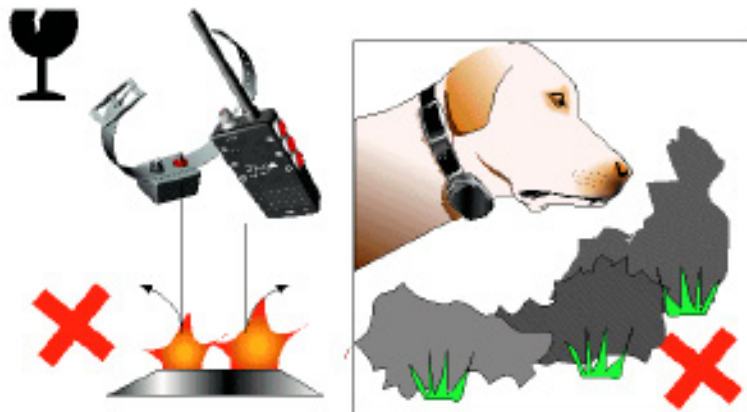

 Although most circuitry is ruggedised, avoid dropping onto hard surfaces.
Avoid using in rocky, fissured terrain

 Never leave collar or transmitter in very warm or sunny areas, or behind glass.
Storage: 1. Charge fully. 2. Store in cool, dry place. 3. Recharge battery every 60 days



 Evitez de laisser tomber votre collier ou télécommande sur des surfaces trop dures.
Cela risque parfois de les endommager

 Ne laissez jamais votre collier ou télécommande dans des endroits trop chauds, tel que voiture en plein soleil. Stockage: 1. Chargez vos batteries avant de les stocker. 2. Protégez vos appareils du soleil et de la chaleur. 3. Rechargez les batteries tous les 60 jours



 Lassen sie den Sender nicht auf eine harte Oberfläche fallen

 Der Empfänger oder Sender sollte nie in einer warme oder sonnige Umgebungen liegen gelassen werden. (Auto im Sommer oder Fensterbank)
Zur Aufbewahrung: 1. Voll laden. 2. Kühl u trocken. 3. Alle 60 Tage einschalten und wenn die Lampe rot blinkt aufladen



 Evitare impatti violenti con superfici rigide. Si sconsiglia l'uso su terreni rocciosi o su crepacci. Non esporre mai il collare o il radiocomando a temperature molto alte (per es. dentro una macchina sotto il sole)

 Nel caso di non uso prolungato :1.caricare preventivamente le batterie prima di riporre l'unita';2. riporre l'unita' al riparo dall'umidita', dal sole e dal calore; 3.ricaricare le batterie ogni 60 giorni



 Voorkom vallen op harde ondergrond. Het grootste deel van de elektronica is redelijk bestendig maar alles heeft een limiet! Voorkom gebruik in een rotsachtig terrein.Laad nooit een band of handset achter in grote hitte of direct zonlicht.plaats nooit achter glas



 Opslag: 1.Volledig laden. 2. Opslaan op een koele en droge plaats. 3. Herlaad de batterij elke 60 dagen

 La mayoría de los circuitos estan hechos a prueba de golpes/caídas, aún así, evítelos.
Evite terrenos escarpados o montañosos

 Nunca deje el collar o el transmisor expuesto a la luz solar o temperaturas extremas.
Guárdese con las baterías recargadas cada 60 días



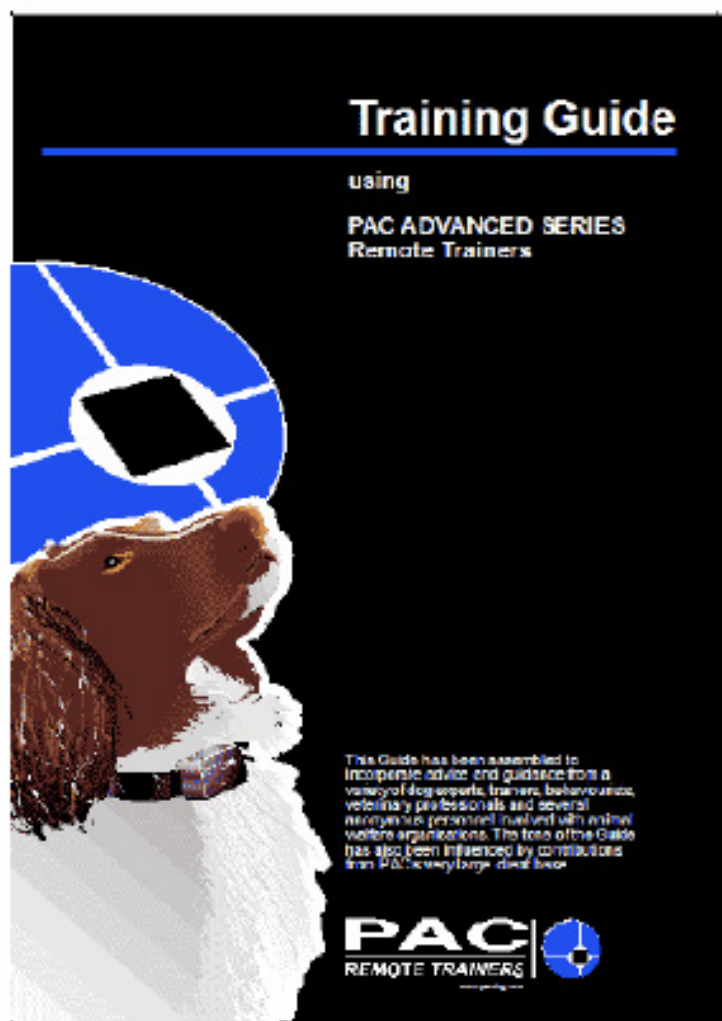

Please read the Training Guide for humane and effective use of your PAC Remote Trainer. It is a comprehensive guide that should enable you to train your dog effectively in a short time. It also offers advice and guidance on training matters.



Lisez le guide d'entraînement pour utiliser de manière efficace et humaine le collier de dressage PAC. Ce guide vous apprend de manière simple et efficace à éduquer votre chien rapidement.



Bitte lesen Sie die Trainingsaufweisungen für menschenfreundlicher und effektiver Gebrauch des PAC Remote Trainer.



Si raccomanda vivamente al fine di usare al massimo delle potenzialità e con il massimo di umanità l'unità addestrativa PAC, la lettura del manuale d'addestramento. È una semplice guida per l'addestramento ottimale del Suo cane in breve tempo ed offre contemporaneamente preziosi consigli per la soluzione dei problemi che si incontrano usando unità radiocomandate.



Lees alstublieft de trainings handleiding voor een humane en effectieve training met uw pac correctie band. Het is een handleiding waarmee het mogelijk moet zijn om in een korte periode uw hond effectief te trainen. Het geeft ook advies over vele anverwante trainings problemen.



Por favor, lea la guía de entrenamiento de su PAC Remote Trainer antes de su uso, le dará los conocimientos básicos para entrenar a su perro de una manera efectiva en poco tiempo.



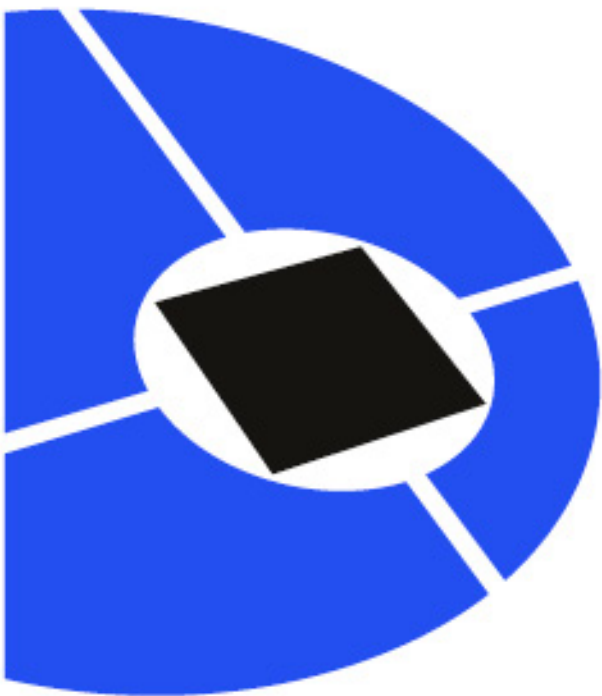

PAC|o

PAC REMOTE TRAINERS



Local Dealer

PAC Products Ltd
Graignamanagh
Co Kilkenny
Ireland
UK Freephone 0800 028 4325
Tel Int.: 353 51423679
Fax Int.: 353 51423964

www.pacdog.com
info@pacdog.com
support@pacdog.com

PAC Repairs
Graignamanagh
Co.Kilkenny
Ireland

made in EU
printed in EU
© PAC Products Ltd. 2006

